

THE INFORMATION CONTAINED IN THIS DRAWING IS THE SOLE PROPERTY OF THE SSC CONTROLS COMPANY AND IS NOT TO BE USED, REPRODUCED, OR DISCLOSED WITHOUT THE EXPRESS WRITTEN PERMISSION OF THE SSC CONTROLS COMPANY.

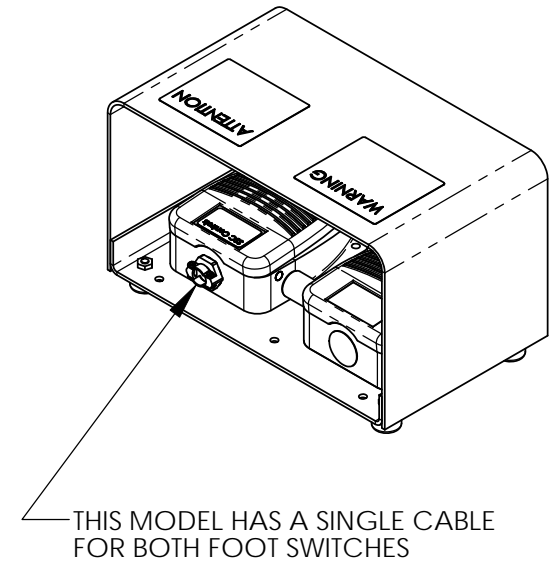
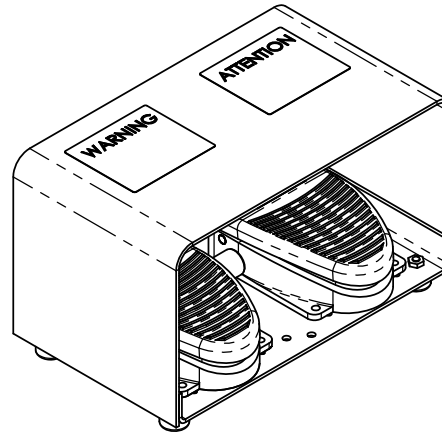
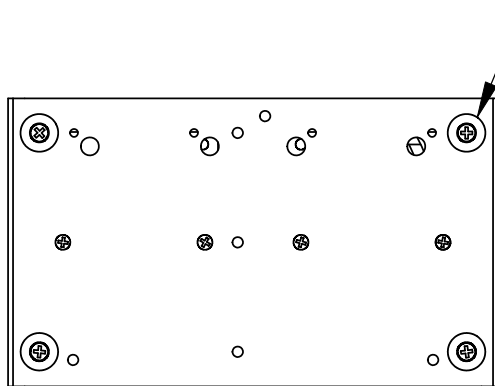
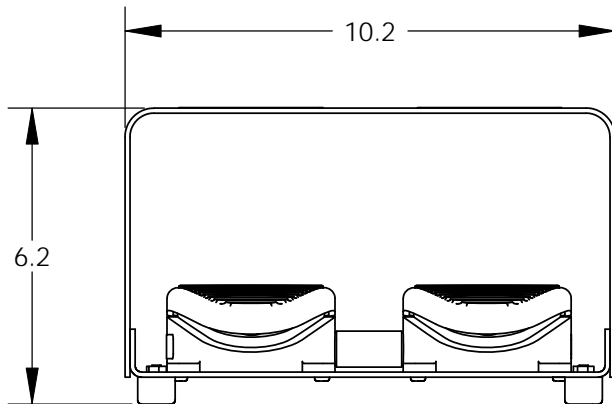
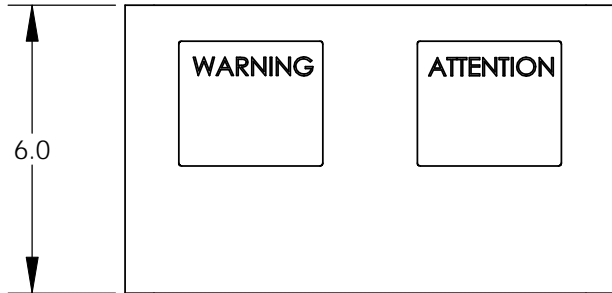

ENCLOSURE RATING:
UL/CSA/NEMA ENCLOSURE TYPE 1
IEC 60529 IP 21

WEIGHT: 10.2 LB (4.6 KG)

NOTES:
ALL DIMENSIONS ARE FOR REFERENCE ONLY.
BUMPER FEET ARE OPTIONAL (CAN BE REMOVED).
GUARD MATERIAL IS POWDER-PAINTED 12-GAUGE STEEL.

THIS MODEL SHOWS THE DUAL GUARD FOR THE DF-SERIES (ONE CABLE FOR BOTH SWITCHES).

EXAMPLE SHOWN: DF200-DG

The SSC Controls Company

8909 EAST AVENUE
MENTOR, OHIO, USA 44060

UNLESS OTHERWISE SPECIFIED,
DIMENSIONS ARE IN INCHES
AND TOLERANCES ARE AS FOLLOWS:

FOR 2 DECIMAL PLACES: ± .02
FOR 3 DECIMAL PLACES: ± .002
FOR ANGLES: ± .5 OF A DEGREE

DRAWING INFORMATION	
DRAWN BY:	BAM
CHECKED BY:	JEM
DATE:	6/24/11
SCALE:	NONE

DRAWING NAME:	
DUAL GUARD FOR DF-SERIES EXTERIOR DIMENSIONS	
DRAWING NUMBER:	N/A