

THE INFORMATION CONTAINED IN THIS DRAWING IS THE SOLE PROPERTY OF THE SSC CONTROLS COMPANY AND IS NOT TO BE USED, REPRODUCED, OR DISCLOSED WITHOUT THE EXPRESS WRITTEN PERMISSION OF THE SSC CONTROLS COMPANY.

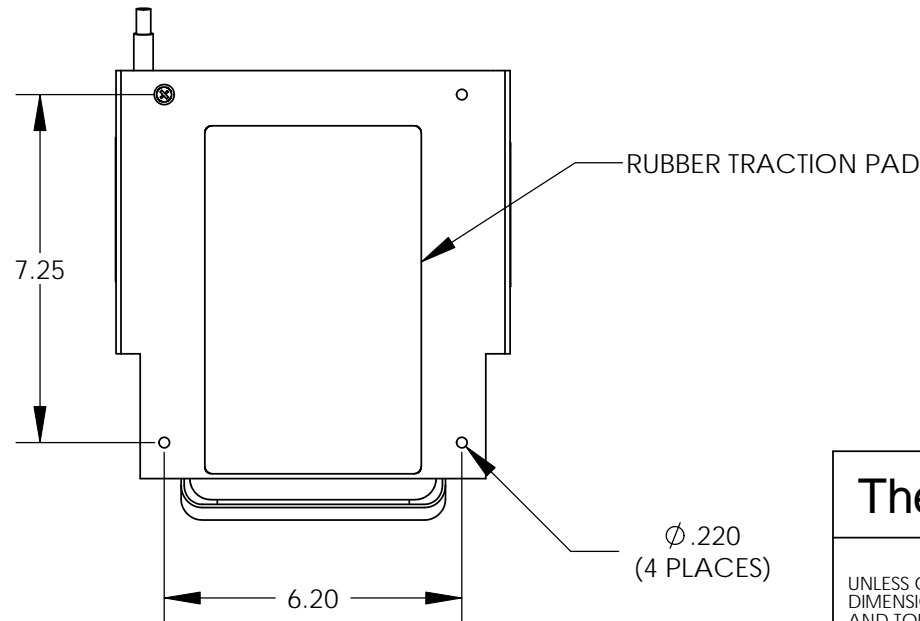
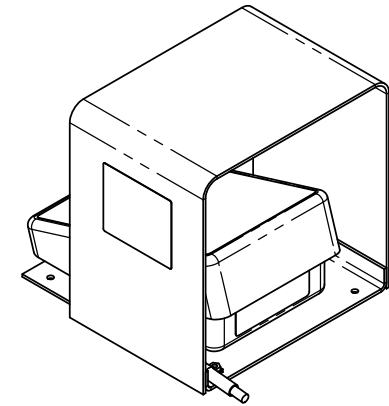
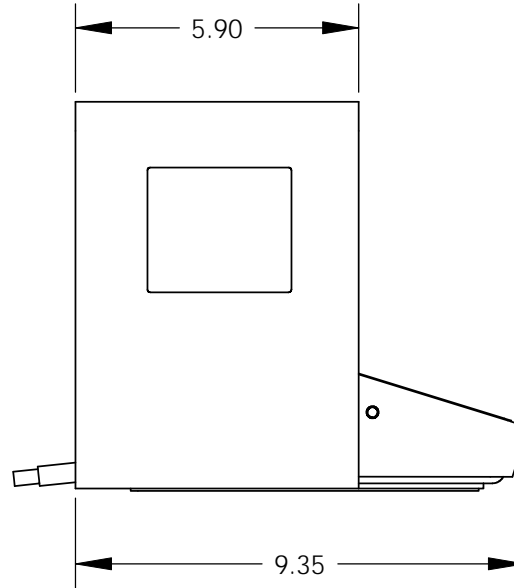
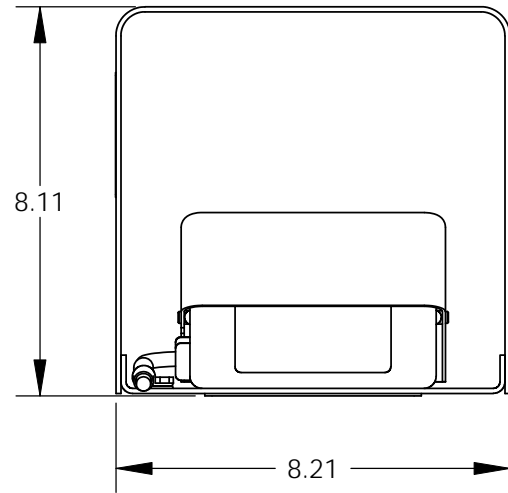

PRODUCT NAME: GUARD FOR L- AND M-SERIES
POTENTIOMETER FOOT CONTROLS ("-G" OPTION)

APPROXIMATE WEIGHT: 10.7 LBS
CABLE LENGTH: 8 FEET

CSA/UL ENCLOSURE TYPE 1
IEC ENCLOSURE RATING IP21

CONTACT INFORMATION:
THE SSC CONTROLS CO.
PH: 440-205-1600
FAX: 440-205-1700
EMAIL: MAIL@SSCCONTROLS.COM
WEBSITE: WWW.SSCCONTROLS.COM

ALL DIMENSIONS ARE FOR REFERENCE ONLY.

<p>The SSC Controls Company</p> <p>UNLESS OTHERWISE SPECIFIED, DIMENSIONS ARE IN INCHES AND TOLERANCES ARE AS FOLLOWS:</p> <p>FOR 2 DECIMAL PLACES: ± .02 FOR 3 DECIMAL PLACES: ± .002 FOR ANGLES: ± .5 OF A DEGREE</p>		<p>8909 EAST AVENUE MENTOR, OHIO, USA 44060</p>	
		<p>DRAWING NAME: L- AND M-SERIES WITH GUARD EXTERIOR DIMENSIONS</p>	
<p>DRAWING INFORMATION</p> <p>DRAWN BY: BAM</p> <p>CHECKED BY: JEM</p> <p>DATE: N/A</p> <p>SCALE: N/A</p>		<p>DRAWING NUMBER: 20248-REF</p>	