

THE INFORMATION CONTAINED IN THIS DRAWING IS THE SOLE PROPERTY OF THE SSC CONTROLS COMPANY AND IS NOT TO BE USED, REPRODUCED, OR DISCLOSED WITHOUT THE EXPRESS WRITTEN PERMISSION OF THE SSC CONTROLS COMPANY.

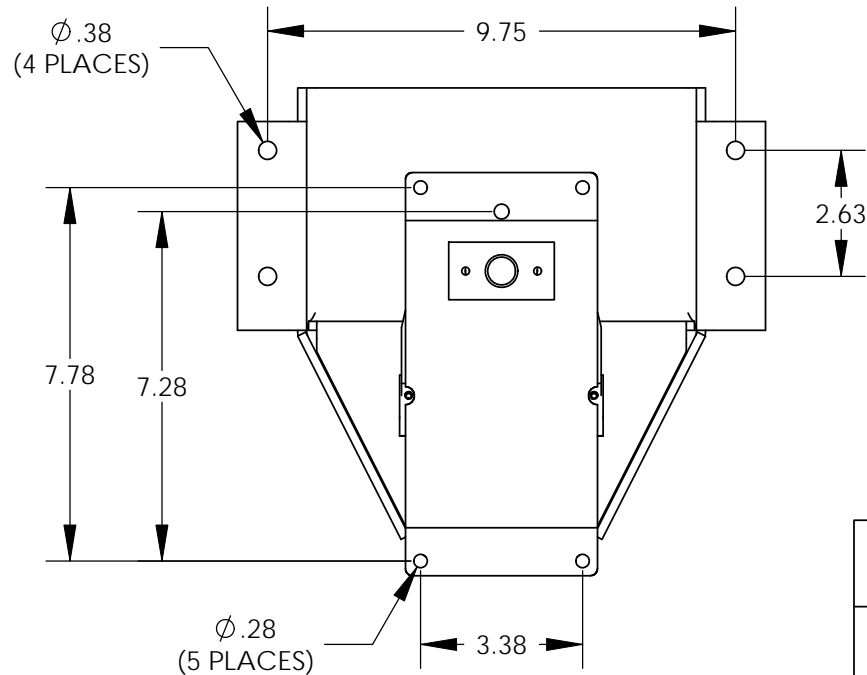
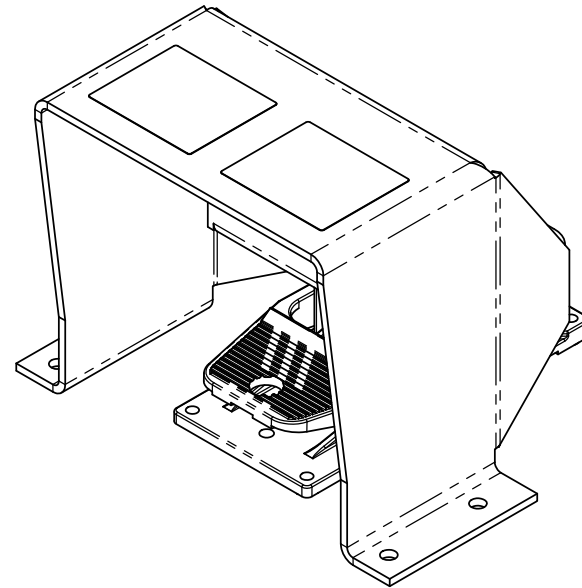
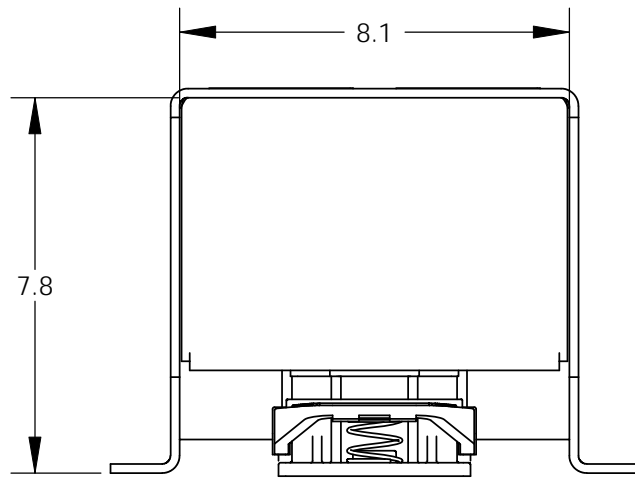

BASE MOUNTING HOLE PATTERN

NEMA ENCLOSURE TYPE 2, 4, AND 13  
IEC ENCLOSURE RATING IP56

GUARD MATERIAL: 3/16" THICK ALUMINUM

APPROXIMATE WEIGHT (G500-MO-G2): 7.4 LBS

CONTACT INFORMATION:  
THE SSC CONTROLS CO.  
PH: 440-205-1600  
FAX: 440-205-1700  
EMAIL: MAIL@SSCCONTROLS.COM  
WEBSITE: WWW.SSCCONTROLS.COM

ALL DIMENSIONS ARE FOR REFERENCE ONLY.

## The SSC Controls Company

8909 EAST AVENUE  
MENTOR, OHIO, USA 44060

UNLESS OTHERWISE SPECIFIED,  
DIMENSIONS ARE IN INCHES  
AND TOLERANCES ARE AS FOLLOWS:

FOR 2 DECIMAL PLACES:  $\pm .02$   
FOR 3 DECIMAL PLACES:  $\pm .002$   
FOR ANGLES:  $\pm .5$  OF A DEGREE

### DRAWING INFORMATION

DRAWN BY: **BAM**

CHECKED BY: **JEM**

DATE: **12/20/11**

SCALE: **1:2**

### DRAWING NAME:

**-G2 GUARD OPTION (8 X 8)**

### DRAWING NUMBER:

**21482**