



THE SSC CONTROLS COMPANY

THE FOOT SWITCH EXPERTS®

Product Information Sheet

BGX500 Dual Foot Switch

The BGX500 Dual Box consists of any two GX-Series foot switches mounted inside the sheetmetal enclosure. The front gate is optional on the left side of the unit (add "-GT" at the end of the model number for the gate). A compartment in the back provides room for wiring and a cable exit out of either side.

Design features:

- Tough sheetmetal 12-gauge enclosure with powder paint.
- Compartment in the back provides room for wiring.
- Openings on either side for cable exit.
- Mounted on four heavy-duty bumper feet.
- Left side gate is optional (add "-GT" to the part number).
- Four threaded holes on top can accommodate a riser for user interface, safety stop switch, or handle.
- Can be equipped with any combination of GX-Series foot switches.

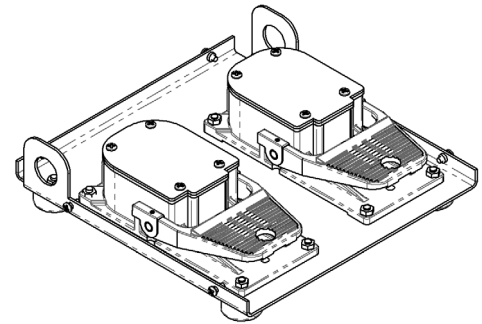

Cover removed to show inside of unit.

Quality features:

- ISO 9001 quality system certified.
- Includes a 1-year warranty on parts and labor.
- Made in USA of imported and domestic components.

Size, L x W x H: 12.2" x 12.0" x 6.4"
Weight (BGX500-MO): 23 pounds
Finish: Safety Orange



Warning: To avoid personal injury, do not use foot switches on machinery lacking effective point-of-operation safeguards. Disconnect input power before installation or maintenance.



Front and back views, shown with optional gate (-GT) on left side.

Model	Description
BGX500	The BGX500 can be equipped with any combination of GX-Series foot switch. For example, a unit with two GX500-MO foot switches is model number BGX500-MO. A unit with GX500-MO on the left side and GX502-AT on the right side is model number BGX500-MO/GX502-AT.
BGX500-GT	Same as above, but also includes gate on left side. Add "-GT" to the end of the part number to include the gate.

The SSC Controls Company
 8909 East Avenue Mentor, Ohio 44060
 Phone: 440 205-1600 Fax: 440 205-1700